

User manual

CTS 600 by Nilan



VP 18 M2

Version: 6.00, 12-03-2012
Software-version: 1.38

 **NILAN**[®]
OUTSTANDING INDOOR CLIMATE

Table of contents

Table of contents	2
Figure table	2
Introduction.....	3
Types of units	4
Review of the thermometer sensors	5
CTS 600 panel	6
How to use the menu:	6
Review of the menus	7
Menus in the CTS 600 control	7
Operating mode.....	8
Main menu	9
Show alarms	10
Show data.....	13
User select.....	14
Setting of clock.....	15
Week programme	16
Factory settings for the 3 weekly programs:	17
Cooling	19
Air exchange.....	20
Air filter	21
Temp. control.....	22
Setting of language	23
Faultfinding.....	24
Maintenance.....	25
Energy saving.....	27
Accessories	28

Figure table

Figure 1: Types of units	4
Figure 2: Diagram illustrating sensor location for VP 18.....	5
Figure 3: CTS 600 panel.....	6
Figure 4: Menu headlines	7
Figure 5: Main menu.....	8
Figure 6: Headlines in the "Main menu"	9
Figure 7: The "Show alarms" menu.....	10
Figure 8: The "Show data" menu	13
Figure 9: The "User select" menu	14
Figure 10: Setting of clock	15
Figure 11: The "Week program" menu	16
Figure 12: The "Hotwater" menu	18
Figure 13: The "Cooling" menu	19
Figure 14: The "Air exchange" menu	20
Figure 15: The "Air filter" menu	21
Figure 16: The "Temp. control" menu.....	22
Figure 17: The "Language" menu	23

Introduction



Please control that the following documents have been delivered together with the unit:

- *Directions for assembly and use*
- *CTS 600 directions (this document)*
- *Electrical chart*

The purpose of this manual is to clearly show the menus and possibilities of the CTS 600 control. The manual may contain functions and facilities which are not available on your system. Unless otherwise stated in the titles, the descriptions apply to all systems listed on page 4.

It is possible to e.g. increase the speed of the exhaustion for a limited period of time.

GETTING STARTED

The system is delivered ready for use.

The factory settings are suitable for most user requirements and it should therefore not be necessary to change any settings other than those found in the main menu. The main menu is described on pages 8 and 9.

Types of units

The control is made for the following ventilation units.

Nr.	Type	Heated air	Frost-protected heating coil	Option for cooling air	High pressure protection	Compressor	De-icing	Water for domestic use
1	VP18 M2	X	X		X	X	X	X
2	VP18 M2 C	X	X	X	X	X	X	X
3	VP18 M2 SUN Cooling Heat exchanger for external heating of water	X	X	X	X	X	X	X

Figure 1: Types of units

Review of the thermometer sensors

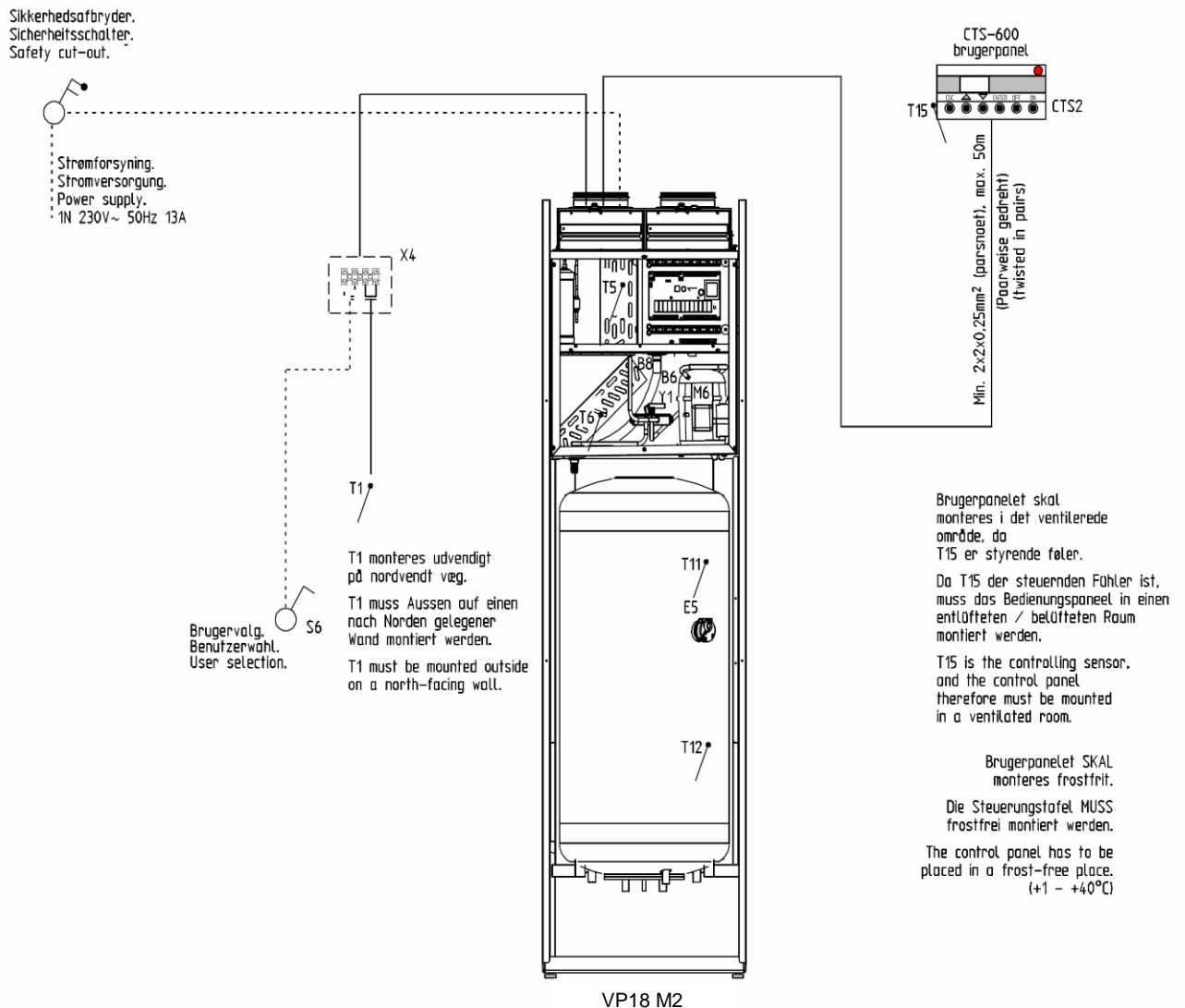

Figure 2: Diagram illustrating sensor location for VP 18

Explanation for figure 2:

- T1 is the thermometer sensor for the fresh air and should be placed at the north side of the building.
- T5 - shows the temperature of the condenser.
- T6 - shows the temperature of the evaporator.
- T11 - is the temperature at the top of the hot water tank.
- T12 - is the temperature at the bottom of the hot water tank.
- T15 - is the thermometer sensor in the CTS 600 panel.

The temperature of the sensors can be read in the "Show data" menu.

CTS 600 panel



Use of the CTS600 panel:

- press ESC to go one step back in the menu
- press ▼▲ to move up or down in a menu or to adjust an activated menu
- press ENTER to activate a menu
- press ENTER to confirm a menu
- press OFF to turn off the unit
- press ON to turn the unit on

Figure 3: CTS 600 panel

The following is indicated by the light-emitting diode at the front of the CTS 600 panel:

Constant yellow light: the compressor is in operation

Flashing yellow: the unit is in alarm condition

The panel can show 2 lines of text with each 8 characters.

The upper line shows a guiding text.

The bottom line shows the matching values to the guiding text.

The text in the display in “on” as long as there is power to the unit and will not turn off even though the unit is set to “off” or has not been operated for a longer period of time.

How to use the menu:

It is possible to adjust a value or a function by finding the matching menu via ▲ or ▼.

To activate the desired menu press **ENTER**.

To adjust the settings of the value press **ENTER** until the value flashes.

The adjustment can now be done via▲▼.

To save the chosen value press **ENTER**.

It is advisable to have the panel and/or the review of the menus near by during the reading of the menus.

If none of the press buttons are activated for one minute the control will automatically return to the main menu.

If you are in the middle of the programming when the control returns to the main menu all data will be saved if they previously are saved by pressing **ENTER**. It is always possible to return to the programming to continue.

Review of the menus

Menus in the CTS 600 control

CTS 600 control has 12 menus (if the unit is with cooling). The control will have the main menu as starting point, (the menu in the full-drawn frame). From here it is possible to go through the other menus via ▲▼.

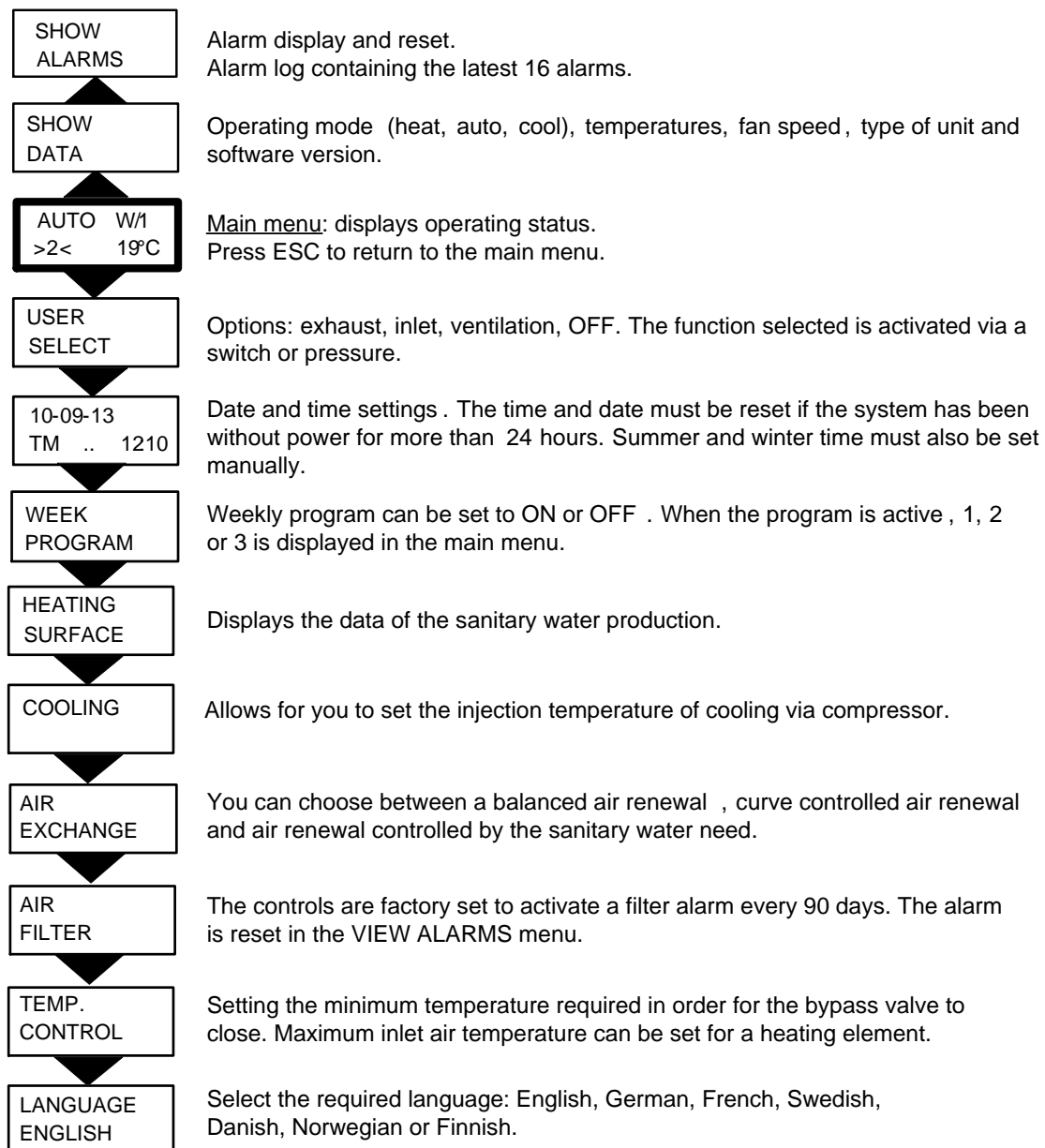

Figure 4: Menu headlines

Operating mode

The main menu shows 3 different values: operating mode, ventilation step and temperature. Those values indicate the state of the unit and are selected by the user.

The main menu is automatically shown 15 seconds after the unit is electrically connected and is now ready to be set.

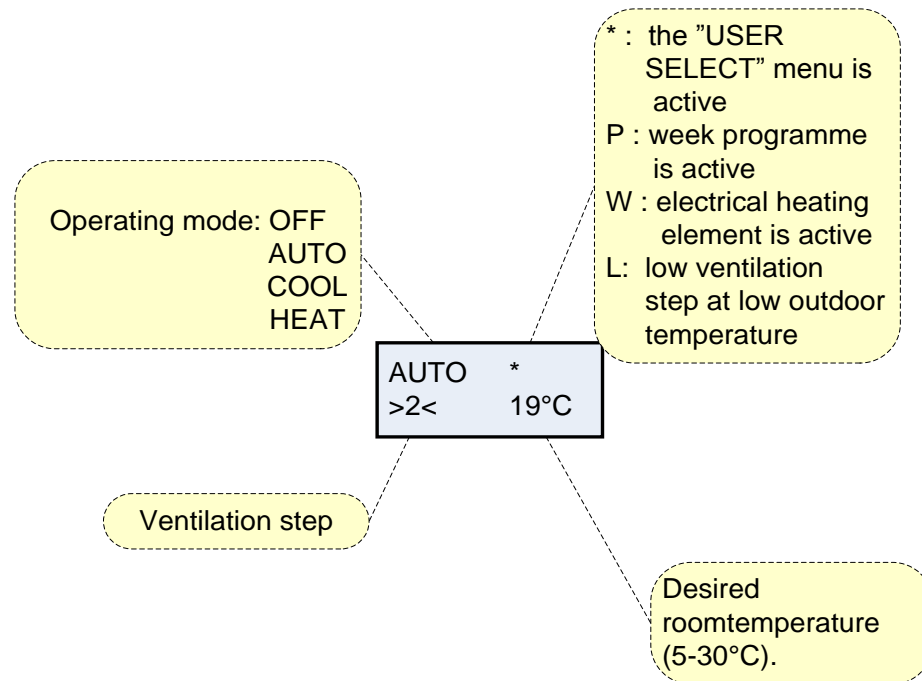

Figure 5: Main menu

Desired room temperature can be adjusted by pressing **ENTER** once. The number at °C flashes and the value can be set via ▲▼. The desired value must be approved by pressing **ENTER** once.

The operating mode can be adjusted by pressing **ENTER** twice. The actual mode is flashing and can be set via ▲▼ and approved by pressing **ENTER** once. In "AUTO"-mode the bypass-draught control is automatically opened or closed according to the temperature setting. As regards cooling there is a neutral zone of 5 °C below room temperature before the unit actively cools via compressor.

The ventilation step can be adjusted by pressing **ENTER** three times. The actual ventilation step is flashing and can be set via ▲▼ and approved by pressing **ENTER** once.

Main menu

The main menu is automatically shown 15 seconds after the unit is electrically connected.
 " " indicates that the menu point flashes and can be set to another value.
 The options available on the main menu are shown in the figure below:

Use of the CTS600 panel:

- press ESC to go one step back in the menu
- press ▼▲ to move up or down in a menu or to adjust an activated menu
- press ENTER to activate a menu
- press ENTER to confirm a menu
- press OFF to turn off the unit
- press ON to turn the unit on

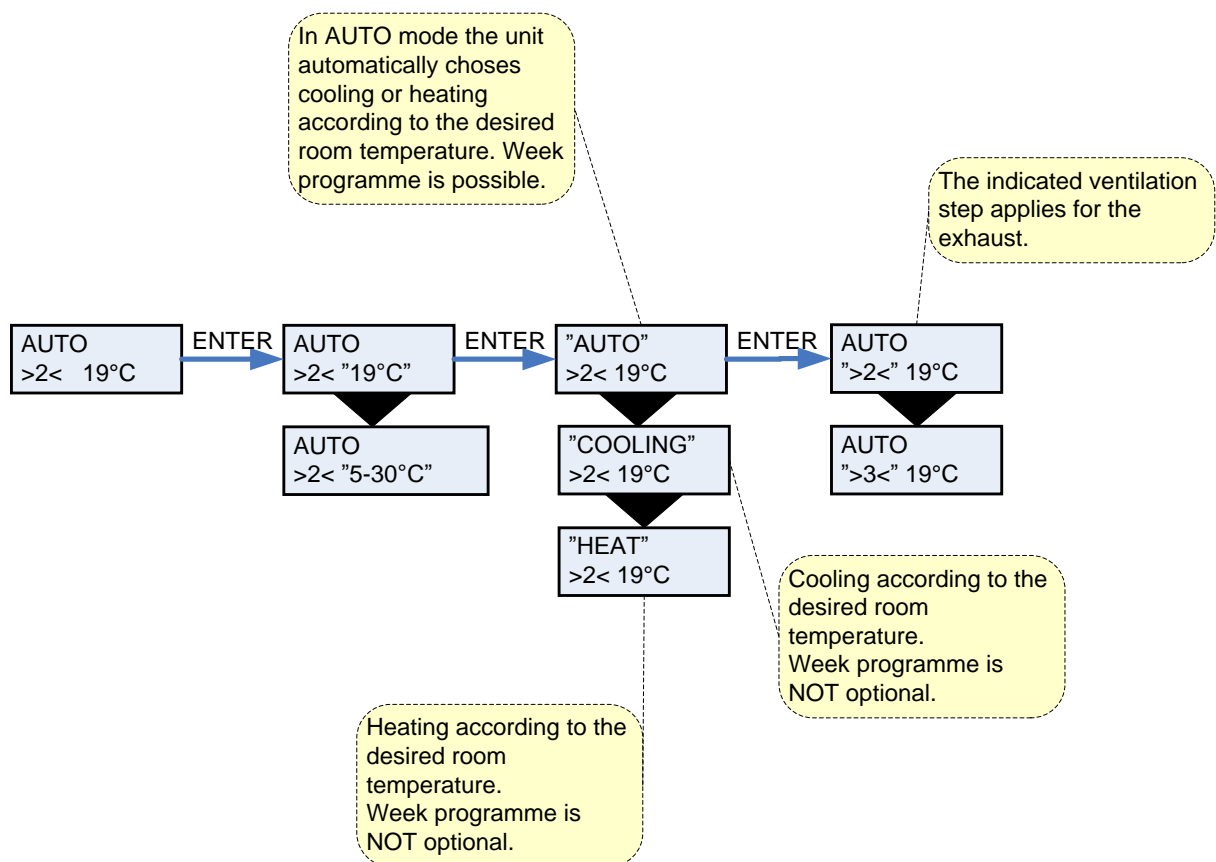

Figure 6: Headlines in the "Main menu"

Show alarms

If the unit is in a state of alarm the yellow light-emitting diode on the front of the CTS 600 panel will flash.

The "Show alarms" menu indicates the type of alarm and the time of the alarm. This is also the menu where the alarm should be reset.

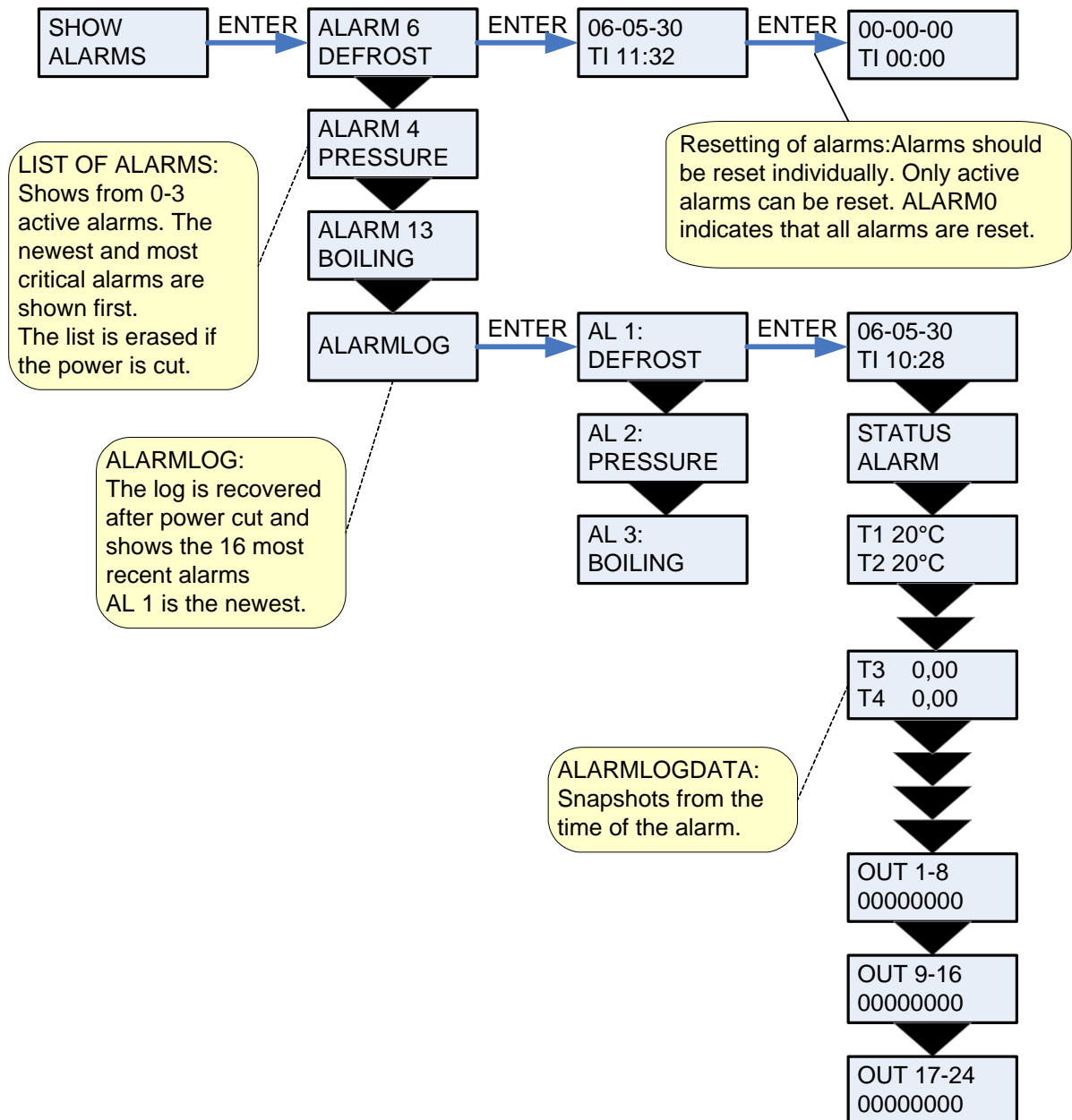

Figure 7: The "Show alarms" menu

Alarm codes are given because of a fault situation or when it is important to inform the user.

The alarms are divided into the following categories:

- C Critical** Operation is partly or completely stopped as long as the alarm is active.
- W Warning** These types of alarms will become critical if the problem is not solved quickly.
- I Informative** Normal operation is not affected. Alarm disappears when it is reset.

Alarm code	Categori	Text in display	Description/ cause	How to remedy alarms
00	--	--	No alarms	
01	C	HARDWARE	Error in control hardware	Contact service if reset does not help
02	C	TIMEOUT	Warning alarm W has become a critical alarm.	Note and reset the alarm. Contact service if alarm does not disappear.
03	C	FIRE	Fire detecting thermostat. Unit is stopped because the fire detecting thermostat has been activated.	If there has not been a fire please contact service.
04	C	PRESSURE	High or low pressure switch in the cooling circuit has been triggered, probably caused by: High pressure: Extreme hot Cloaked filter Defective fan Low pressure: Extreme cold Unit might have lost coolant Cloaked filter Defective fan	Check for errors and reset alarms. If you are unable to reset the alarm or if the alarm occurs often please contact service.
06	C	DEFROST	The unit is defrosting. The frost protection of the heat recovery system is insufficient and the unit will stop. This can be caused by extreme low outdoor temperatures	Contact service if reset does not help. Note the actual sensor temperatures from the menu "Show data" to help service.
08	C	FROST	One of the temperature sensors in the unit is short circuit or defect.	Note the sensor and contact service.
09	C	OVERTEMP	One of the temperature sensors in the unit is disconnected or defect.	Note the sensor and contact service.
13	C	BOILING	Boiling protection of the hot water	Contact service

Alarm code	Categori	Text in display	Description/ cause	How to remedy alarms
15	W	ROOM LOW	When room temperature drops below 10°C the unit will stop in order to protect the house from further cooling down. The function is useful when the house is not occupied and the main heating has stopped.	Heat up the house and reset the alarm
16	I	SOFTWARE	Error in software	Contact service
17	I	WATCHDOG	Error in software	Contact service
18	I	CONFIG	Parts of the programming are lost and can be caused by a longer period of power failure or lightning. The unit will keep on operating on standard programming.	Reset alarm Re-programme the week programme. Contact service if the unit does not operate as before. Supplementary programs can be lost. Only service can access the supplementary programs and menus.
19	I	FILTER	The filter guard is set to give alarm when a pre-set period of time has occurred	Clean /replace filter and reset alarm
20	I	LEGIONEL	Legionella temperature has not been reached within the time limit	Contact service
21	I	POWER	Occurs if power has been cut off for a longer period of time	The week programme should be checked and adjusted if necessary. Reset alarm.

Show data

The actual operation data can be read in the "Show data" menu.

See review of thermometer sensors at page 5.

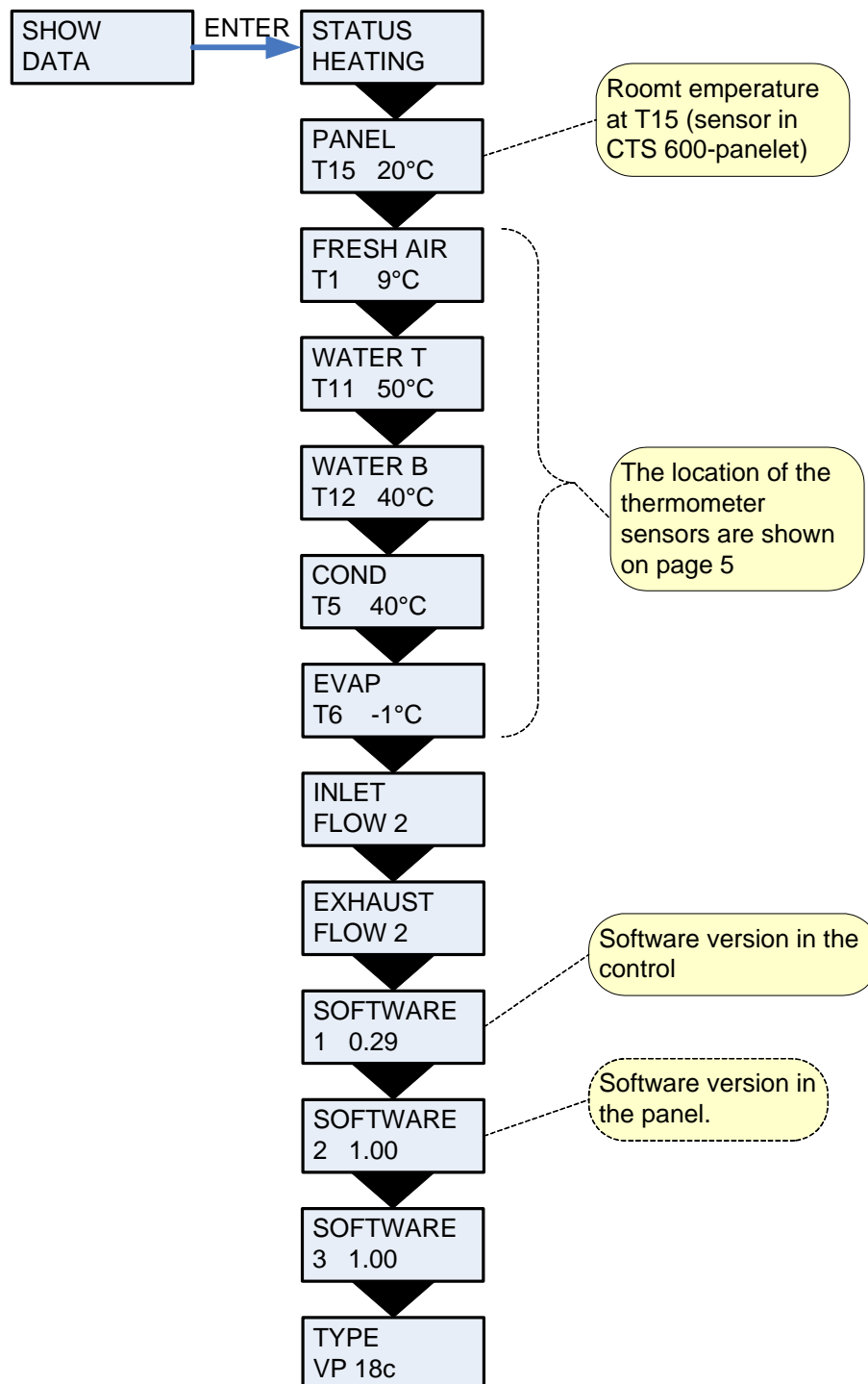

Figure 8: The "Show data" menu

User select

In the "User select" menu it is possible to overrule the operation mode in the main menu. It is possible to e.g. increase the speed of the exhaust for a limited period of time.

If the ventilation step and/or temperature is being adjusted in the main menu any active user selections are deleted.

If user selections are active due to external switches the function cannot be deleted.

" " indicates that the menu point flashes and can be set to another value.

Use of the CTS600 panel:

- press ESC to go one step back in the menu
- press ▼▲ to move up or down in a menu or to adjust an activated menu
- press ENTER to activate a menu
- press ENTER to confirm a menu
- press OFF to turn off the unit
- press ON to turn the unit on

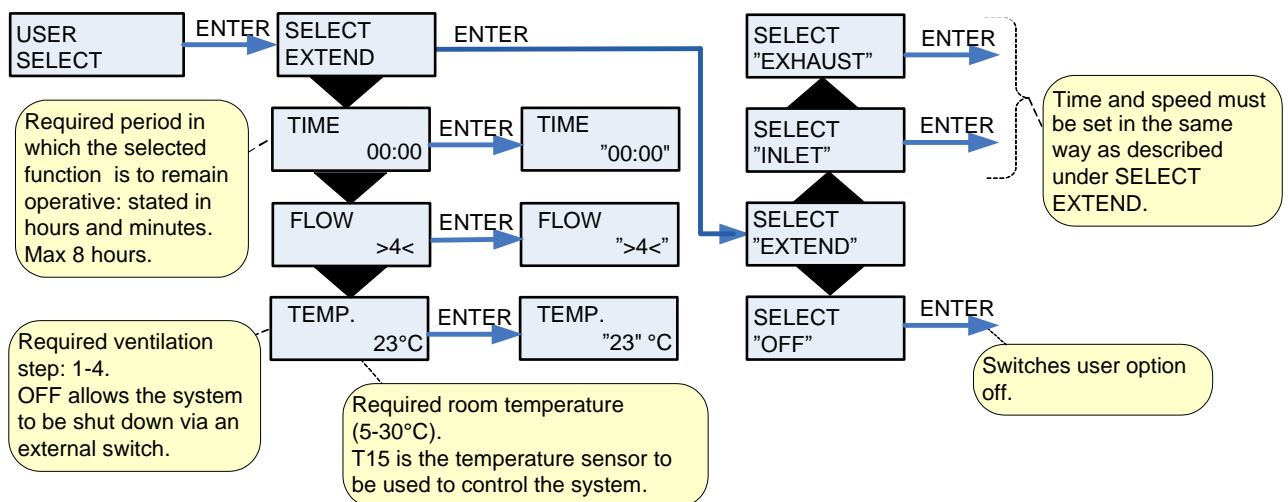

Figure 9: The "User select" menu

Setting of clock

In case of power cut the clock will function for at least 24 hours. If the time function is lost there will be a alarm.

Changing to daylight saving time has to be done manually.

” ” indicates that the menu point flashes and can be set to another value.

Use of the CTS600 panel:

- press ESC to go one step back in the menu
- press ▼▲ to move up or down in a menu or to adjust an activated menu
- press ENTER to activate a menu
- press ENTER to confirm a menu
- press OFF to turn off the unit
- press ON to turn the unit on

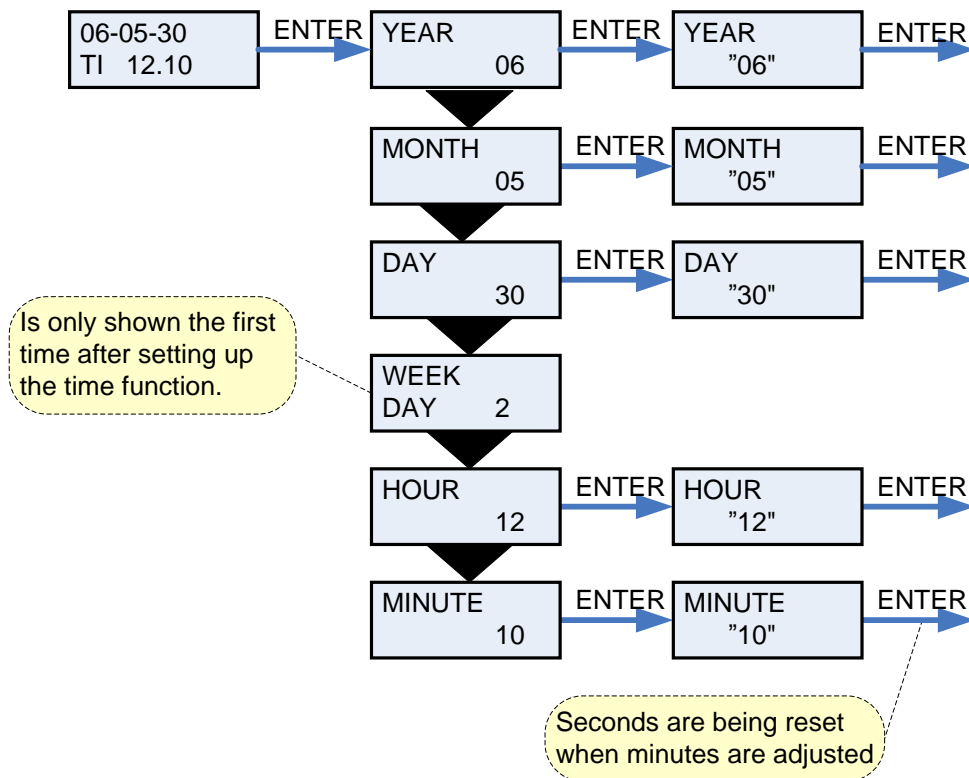

Figure 10: Setting of clock

Week programme

The unit is equipped with 3 standardized week programmes. Anlægget er fra fabrikken indstillet til program 1.

In addition to these programmes it is possible to programme your own week programme which can be one of the standard programmes with minor alterations.

” ” indicates that the menu point flashes and can be set to another value.

- Use of the CTS600 panel:

 - press ESC to go one step back in the menu
 - press ▼▲ to move up or down in a menu or to adjust an activated menu
 - press ENTER to activate a menu
 - press ENTER to confirm a menu
 - press OFF to turn off the unit
 - press ON to turn the unit on

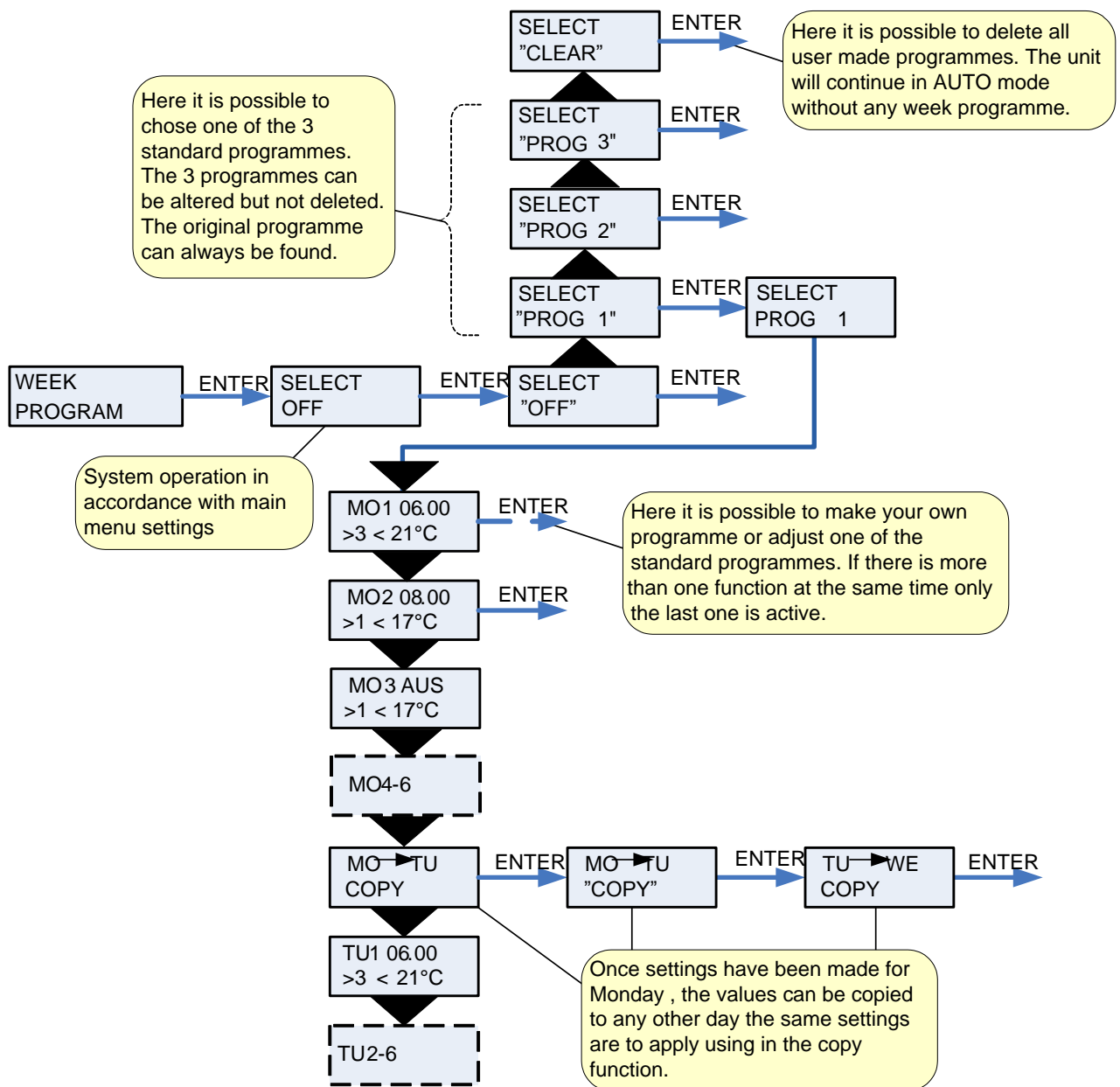

Figure 11: The "Week program" menu

Factory settings for the 3 weekly programs:

Program 1 is suitable for the working family
 Program 2 is suitable for the non-working family
 Program 3 is suitable for offices

Program	Week day	Function	Time	Ventilation	Temperature
Program 1	Monday - Friday	1	6.00	3	21
		2	8.00	1	21
		3	15.00	3	21
		4	22.00	1	21
	Saturday - Sunday	1	8.00	3	21
		2	23.00	1	21
Program 2	Monday - Sunday	1	8.00	3	21
		2	23.00	1	21
Program 3	Monday - Friday	1	7.00	3	21
		2	16.00	OFF	21

Weekly program settings

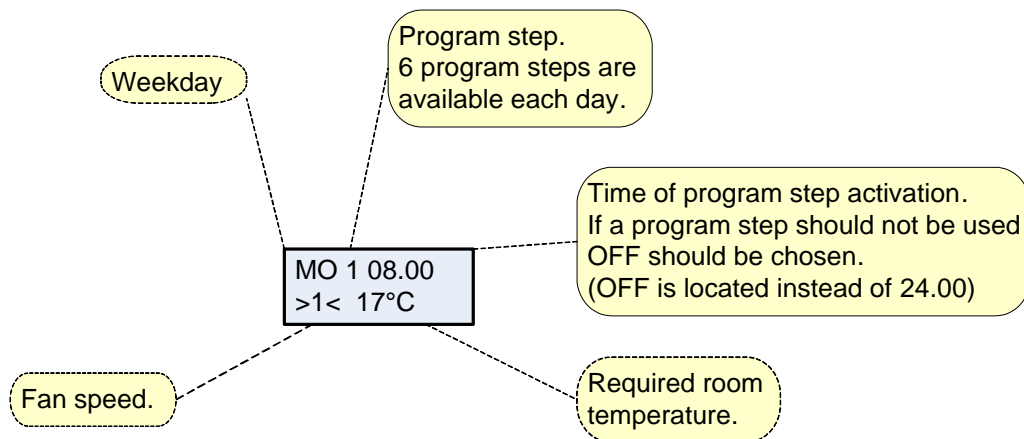

Hot water

The "Hot water" menu shows the data for production of hot water.

" " indicates that the menu point flashes and can be set to another value.

Use of the CTS600 panel:

- press ESC to go one step back in the menu
- press ▼▲ to move up or down in a menu or to adjust an activated menu
- press ENTER to activate a menu
- press ENTER to confirm a menu
- press OFF to turn off the unit
- press ON to turn the unit on

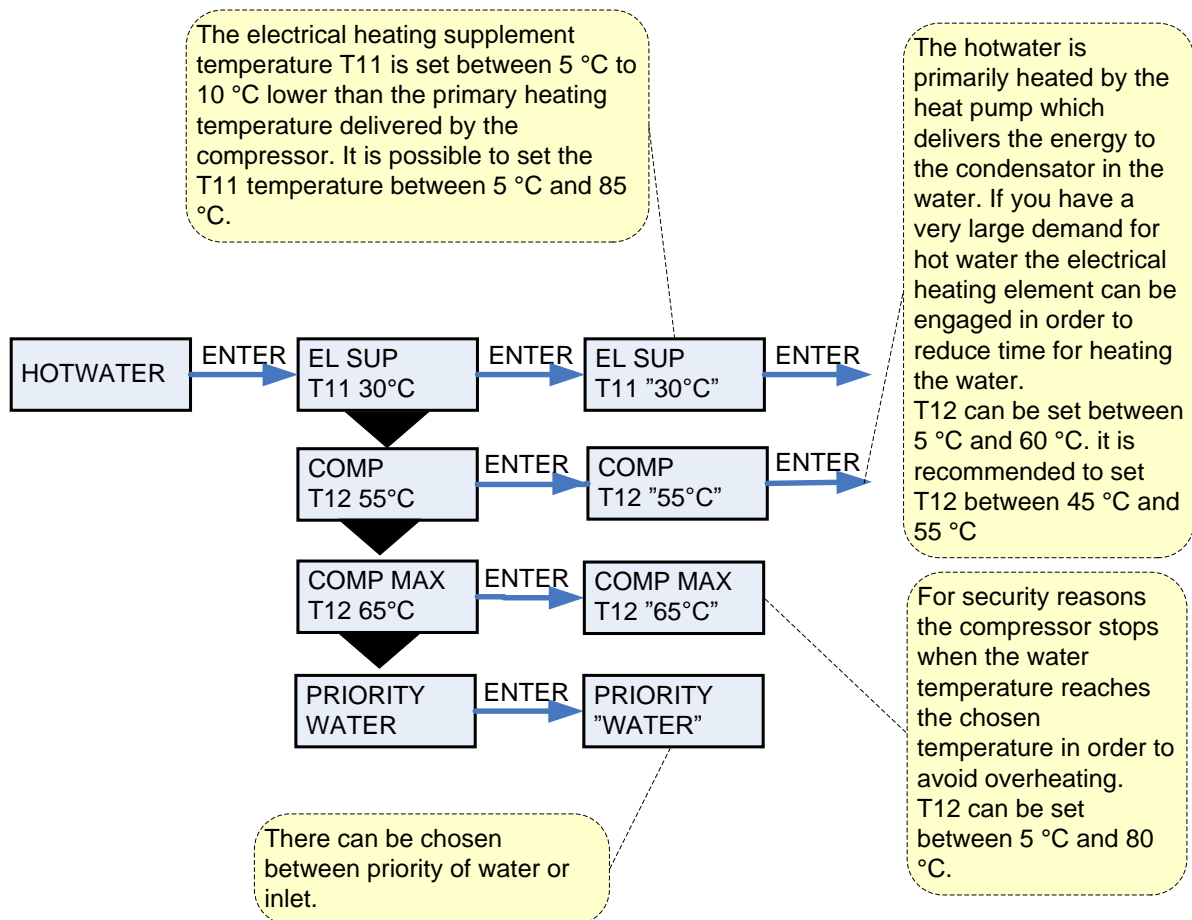

Figure 12: The "Hotwater" menu

Cooling

The menu COOLING can only be accessed in the control panel when the system is a VP 18 Cooling

The "Cooling" menu enables you to chose at which temperature cooling should be activated according to the room temperature.

" " indicates that the menu point flashes and can be set to another value.

Use of the CTS600 panel:

- press ESC to go one step back in the menu
- press ▼▲ to move up or down in a menu or to adjust an activated menu
- press ENTER to activate a menu
- press ENTER to confirm a menu
- press OFF to turn off the unit
- press ON to turn the unit on

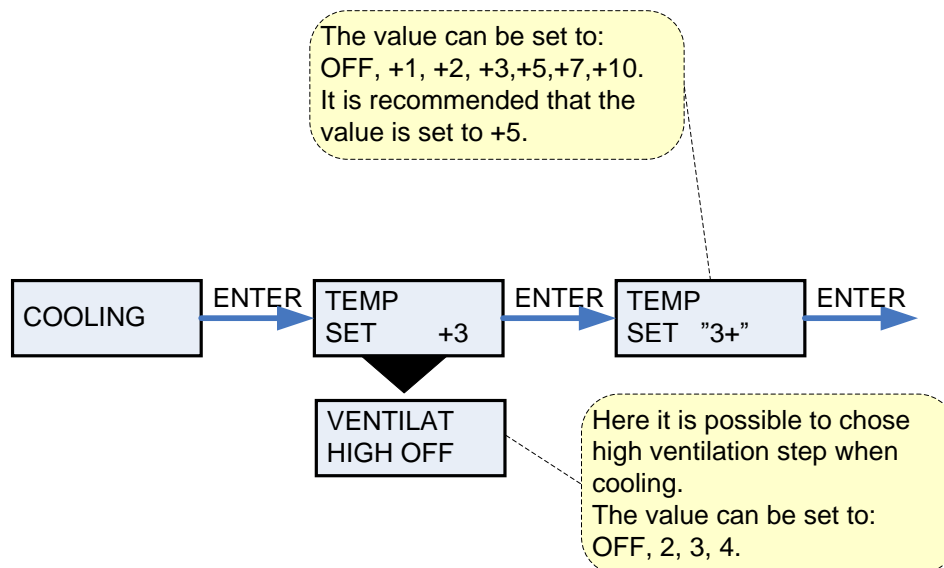

Figure 13: The "Cooling" menu

Example:	Chosen room temperature in the main menu	=	21°C
	<u>Cooling point</u>	=	<u>5°C</u>
	Start compressor cooling operation mode	=	<u><u>26°C</u></u>

Air filter

In the "Air filter" menu it is possible to choose the interval of the filter guard.

The interval is preset to a 90 day interval.

" " indicates that the menu point flashes and can be set to another value.

Use of the CTS600 panel:

- press ESC to go one step back in the menu
- press ▼▲ to move up or down in a menu or to adjust an activated menu
- press ENTER to activate a menu
- press ENTER to confirm a menu
- press OFF to turn off the unit
- press ON to turn the unit on

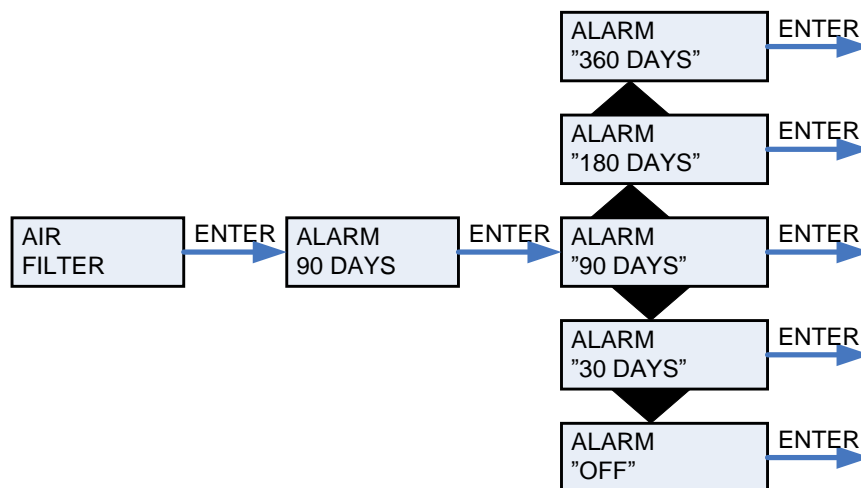

Figure 15: The "Air filter" menu

Temp. control

In the "Temp. control" menu it is possible to set the highest and lowest inlet temperature.

" " indicates that the menu point flashes and can be set to another value.

Use of the CTS600 panel:

- press ESC to go one step back in the menu
- press ▼▲ to move up or down in a menu or to adjust an activated menu
- press ENTER to activate a menu
- press ENTER to confirm a menu
- press OFF to turn off the unit
- press ON to turn the unit on

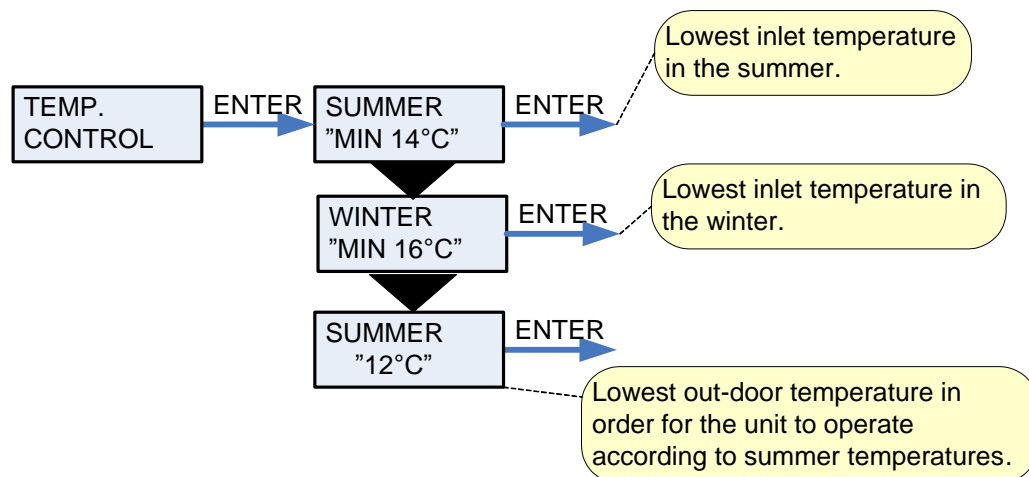

Figure 16: The "Temp. control" menu

At outdoor temperatures lower than set value (measured at T1) cooling via compressor is blocked.

Setting of language

In this menu you set which language to be used in the CTS 600 panel.

” ” indicates that the menu point flashes and can be set to another value.

Use of the CTS600 panel:

- press ESC to go one step back in the menu
- press ▼▲ to move up or down in a menu or to adjust an activated menu
- press ENTER to activate a menu
- press ENTER to confirm a menu
- press OFF to turn off the unit
- press ON to turn the unit on

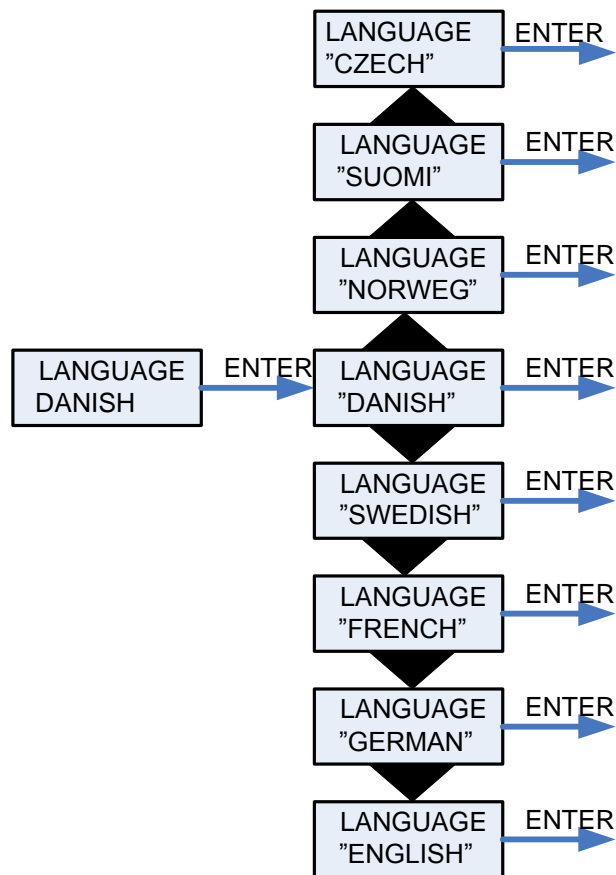

Figure 17: The "Language" menu

Faultfinding

If there should be any operating errors please inspect the following before contacting your service mechanic:

Check if the alarm diode on the CTS 600 panel is flashing. If this is the case please read the alarm in the “Show alarms” menu and correct the fault. If necessary please contact your local service mechanic. Alarm codes and directions for correcting alarms can be found in the CTS 600 directions.

- **VP18 is functioning but with reduced output.**

Please inspect if the unit is supplied with enough air. Check the filters and control that the air valves are sufficiently opened. In 98% of the cases the fault derives from obstructed filters. The ventilators can be set on a higher speed if necessary. Any draught controls to the outside should be closed at outside temperatures below 6°C.

- **VP18 is functioning but there is no hot water.**

Please check if the hot water tank is emptied. If the unit is supplied with hot-water circulation and the pipes are not insulated there can be a significant heat-loss which can cause a reduced output of the VP18.

Is the water temperature adjusted correctly in the CTS 600 control? (T12). The temperature should normally be set to 45–55°C. How to adjust the temperature please see the CTS 600 directions (delivered together with the VP18).

Is the air supply too cold or is the air flow too little? Please check the filters and valves and if the insulation of the ducts is sufficient and dense.

- **VP18 is not functioning.**

Please inspect the fuse. Check if the safety thermostat for hot water has disengaged the electricity. If this is the case please press the button and the thermostat will connect when the water temperature has dropped 10–15°C. If the thermostat disengages the electricity several times please contact your service mechanic.

Maintenance

At least every 3 months:

- The filters should be cleaned and renewed when needed. Usually the filters need to be renewed once a year.
The filter guard in the CTS 600 control can be used in order to make sure that the filters are checked. Please see CTS 600 directions for further information. (delivered together with the VP18).

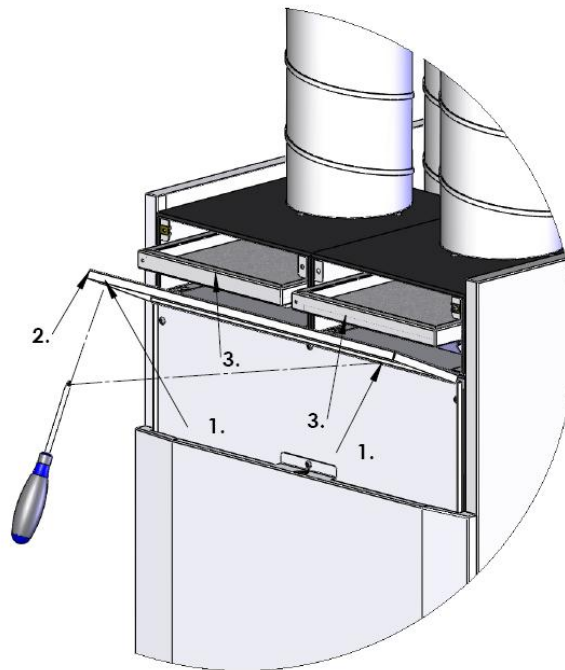

- Changing filters:
1. loosen the screws
 2. remove the filter door
 3. pull the filter frames out to remove/clean the filters.

Once a year:

- The sacrificial anode should be inspected and renewed if it is much corroded. The hot-water tank can corrode if the anode is left unchanged.

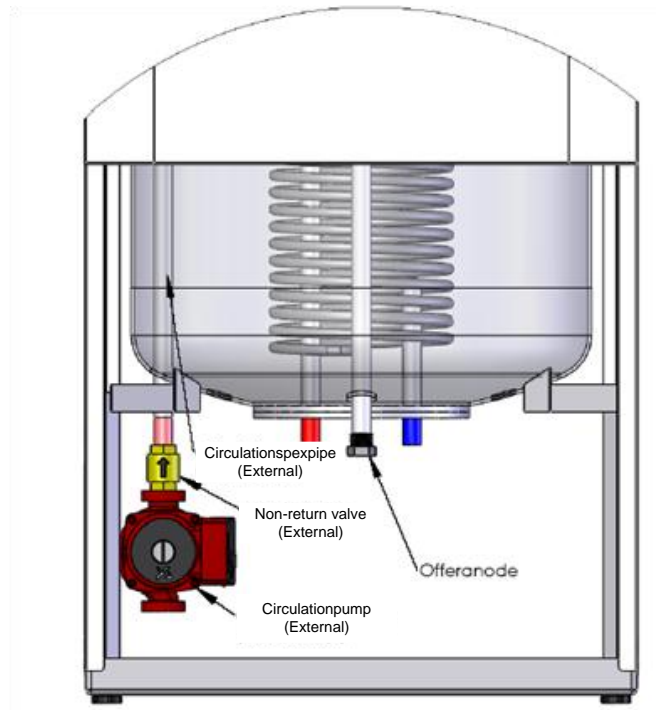

- The intake should be inspected and any uncleanness should be removed.
- The evaporator should be inspected and cleaned.
- It should be checked that the condensate has free passage through the water seal and the condensation drain.
- The safety switch for the hot water tank should be controlled.
- It is recommended to take out a subscription for service.

Energy saving

- Use the setting "Energy" in the "Air exchange" menu in the CTS 600 control. Please see CTS 600 directions for further information. (delivered together with the VP18).
- Keep the hot-water at a low temperature. Try with 45°C.
- The auxiliary heating element should be cut off and only be used at very large hot-water demands. Please see CTS 600 directions
- The ventilation speed should not be set higher than necessary.
- Avoid hot-water circulation.
- Spread out the bathing times as the VP18 Combi needs 6-7 hours to heat the 180L water.
- Insulate the ducting as prescribed.
- Do not cool during winter time.

Accessories

Filters		
<i>Type</i>	<i>Qty.</i>	<i>Nilan itemnr.</i>
Filter (1pair = 2pcs.)	1	8485
Pollen filter F7 to insert in VP18 M2 unit	1	39542

Accessories/spare parts		
<i>Type</i>	<i>Qty.</i>	<i>Nilan itemnr.</i>
Hygrostat	1	3637
CTS 600, control PCB	1	23991
CTS 600, control panel complete	1	2398
CTS 600, white control panel enclosure	1	2398HX
Heating cable for condense outlet (frost protection)		2172